

NFC Poster- spec sheet



NFC Smart Poster is a new way of marketing. More and more brands use it to attract more users to participate in their activities, as well as improve the brand image. Estée Lauder and Samsung have already used NFC posters in marketing campaigns several years ago. Moreover, you would always see the NFC poster used for film promotion.

Parameters

| | | | | | |
|-----------|--|------------------|---|---------------------|--|
| Item | NFC Smart Poster | Color | Custom | Working Temperature | -30°C to 200°C |
| Material | Paper | Size | φ15 mm, φ20 mm, φ 27 mm, φ30 mm φ33 mm, φ 34 mm, Or custom | Data Retention Time | 10 years |
| Chip | NTAG213, Ntag216, TOPAZ512, NTAG215, F08, DESFIRE 2K 4K 8K, etc | Memory | depend on chip | Printing Options | Silk-screen printing, Laser Engraving, CMYK full color, Pantone, etc. |
| Frequency | 13.56 MHz | Reading Distance | 1-5cm | Write Endurance | 100000 times |
| Protocol | ISO14443A | | | | |

Dimensional Diagram

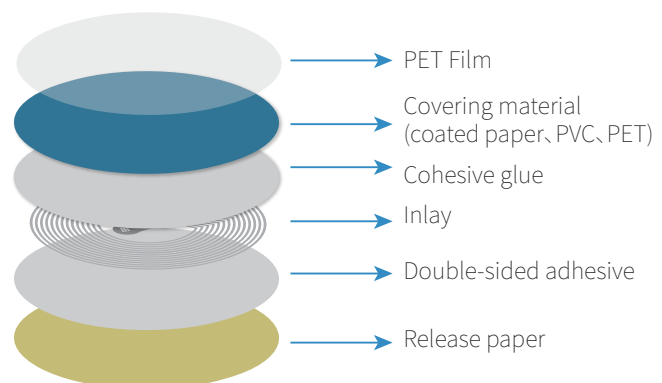
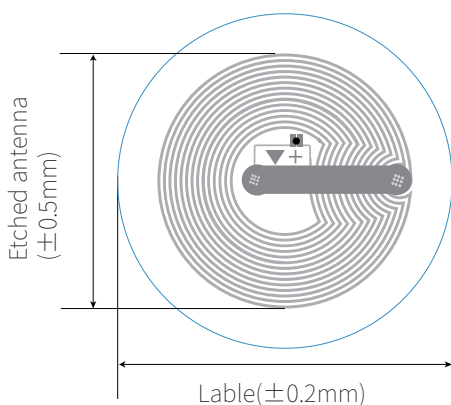

Feature

- ▶ Working on 13.56 MHz frequency
- ▶ Can realize the mobile phone interaction
- ▶ Easy to use and low cost
- ▶ Contactless reading, Security and intelligence
- ▶ Various chips, sizes, shapes, colors are available
- ▶ Support all NFC-enable cellphone or other NFC devices
- ▶ Printable that you can put any pattern on it
- ▶ Diverse Crafts are available
- ▶ Support for custom service

Available chips

HF 13.56 MHz Chips

| Chip Name | Protocol | Capacity | Frequency |
|-----------------------|-----------|-----------|-----------|
| Ntag213 | ISO14443A | 180 byte | 13.56 MHz |
| Ntag215 | ISO14443A | 540 byte | 13.56 MHz |
| Ntag216 | ISO14443A | 924 byte | 13.56 MHz |
| MIFARE Classic 1K | ISO14443A | 1 KB | 13.56 MHz |
| MIFARE Classic 4K | ISO14443A | 4 KB | 13.56 MHz |
| MIFARE Ultralight EV1 | ISO14443A | 80 byte | 13.56 MHz |
| MIFARE Ultralight C | ISO14443A | 192 byte | 13.56 MHz |
| ICODE SLIX | ISO15693 | 1024 bits | 13.56 MHz |

APPLICATIONS

- Film promotion
- Market campaign
- Other applications
- Brand publicity
- Intelligent advertising
- Exhibition activities
- Concert promotion